

TEMPERATURE DISTRIBUTION FOR TRIMMER CAPACITOR WITH MODIFIED CONTACT FINGERS OF K-130 CYCLOTRON

Bidhan Ch Mandal, Manir A, Subrata S, Pranab B, Biswanath M, Anjan DG, Sarkar S C, Adak D, Jayanta Chaudhuri and Dr. Rakesh Bhandari.
Variable Energy Cyclotron Centre, 1/AF Bidhan Nagar, Kolkata 700064

Abstract

K-130 Room Temperature Cyclotron is delivering the charged particle beams of different species for more than the last three decades. It has recently gone through a major up-gradation with PIG source for delivering beam primarily for the Radioactive Ion beam (RIB) experiments and basic physics research. The RF system with its fine tuner i.e. Trimmer capacitor's efficient performance is the key tool for Cyclotron Operation.

The Trimmer capacitor is the fine tuning tool (~100 kHz) of the $\lambda/4$ horizontal RF cavity. The capacitor is in the beam chamber vacuum of 3×10^{-6} mbar. The capacitor has two major parts—Stator and Rotor. Plate type Rotor and Stator are made of Al-6061T6 and cooled by LCW at the periphery only. The support plate of the Rotor is exposed to high vacuum in one side and atmosphere on the other side. The housing cum Trimmer Rotor gets heavily heated while operating at higher RF frequency with previous contact spring.

This paper describes thermal analysis of the trimmer to find out the temperature distribution to evaluate the hot spot temperature. At present, cyclotron is operating with Trimmer capacitor with modified contact finger.

INTRODUCTION

The Cyclotron operates at ~ 70 kV in 5.5 - 16.5 MHz frequency range depends upon the requirement. Presently, the Cyclotron is operating with PIG based ion source for Alpha beam (${}^4\text{He}^{2+}$) / Proton beam (${}^1\text{H}^{1+}$) with different energy for various experiments. The coarse frequency tuning is done by changing cavity volume through movable RF panels while online fine tuning is done by oscillating Trimmer capacitor. The Rotor of this plate type Trimmer capacitor is connected to Resonator tank (RT) through a stationary Trimmer housing. Cavity can be fed RF power to 250 kW through Barle-4648 tube. Heat load due to surface loss over the Trimmer rotor components is about 4-8 kW. Heat load gets dissipated by LCW cooling at the periphery and partly by the ambient air cooling at the Trimmer housing outer surface. Heat dissipation by radiation from the rotor is also comparably negligible. The housing is rigidly connected to Resonator Tank (RT tank) through an "O" ring based vacuum seal and through Be-Cu contact spring based RF contact. The cooling loop of Trimmer rotor (see Fig.1) carries 10 lpm low conductivity water (LCW) @10 kg/cm² supply pressure. The last few decades's operating data hints no

comparable temperature increase on the housing outer surface at ~ 60MeV alpha beam. Recently, the same housing gets heated to a comparable temperature while the cavity is being tuned for higher energy application.

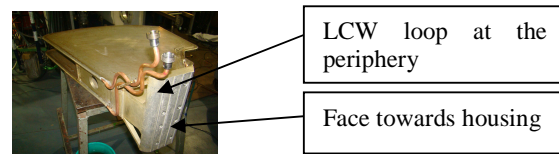

Figure 1: Trimmer Rotor

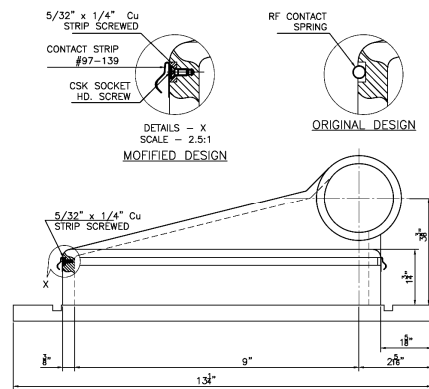

Figure 2: Schematic view of Trimmer Capacitor Housing with Be-Cu Contact Finger

Trimmer rotor is connected by Be-Cu contact fingers at the shaft ends and the housing was connected to RT tank wall with contact spring. Over the years, these components gets distorted and worn out. Moreover, the assembly of Trimmer rotor housing is really a tough task keeping the Be-Cu contact spring intact due to total inaccessibility that results no assurance on the contact spring position. This has solved by replacing with new contact fingers at the shaft interface as well as Be-Cu contact fingers brazed on a Cu strips and subsequently mounted in place of contact springs (see fig.1 & 2). A Thermal analysis and distribution of temperature of the Trimmer rotor along with housing gives an analytical picture to assess the above.

THEORY

Considering friction and bend losses in the cooling loop, following relation

$$\left(\frac{v^2}{2 * g} + f * \frac{l * v^2}{2 * g * D} + \frac{\zeta * v^2}{2 * g} * n \right) - \frac{p}{g * \rho} = 0 \quad \text{--- Eqn.1}$$

gives v, fluid average velocity in LCW loop. The rotor plate is exposed to volumetric heat generation and is

being cooled by LCW convection boundary and subsequent conduction along the plate with components followed by the natural convection of air outside RT wall.

Convection coefficient, h , at the tube fluid boundary, can be computed from $Nu = 0.023.Re^{0.8}.Pr^{0.4}$ as per Dittus-Boelter equation for heating & $h = Nu.Kf/D$, $Q = \pi.d^2.v/4$, where, f = friction factor for tubes either from Moody's diagram or by Blasius formula, l = length of cooling loop, D = Inner diameter of tube, μ = viscosity of water, ζ = bending loss co-efficient, n = nos. of bends in the loop, p = pressure difference, ρ = density of water, Kf = Conduction coefficient, Q = flow rate, Pr = Prandtl no., Re = Reynolds's no., Nu = Nusselt no., h = coefficient of convection, T_w = average fluid (LCW) temperature, g = gravitational acceleration.

From energy balance equations and Finite Difference Method (FDM), discretization and subsequent iterative calculation can be made by Excel based on Nodal Finite Difference Equations e.g.

$$T_{m,n+1} + T_{m,n-1} + T_{m+1,n} + T_{m-1,n} + q(\Delta x)^2/k - 4T_{m,n} = 0, \quad \text{-- at the mid nodes/ grids}$$

$$\text{Or, } 2.T_{m,n}(h.\Delta x/k + 1) - 2.h.\Delta x.T_w/k - (T_{m,n-1} + T_{m,n+1}) - q(\Delta x)^2/2k - 4T_{m,n} = 0 \quad \text{-- at the convection boundary}$$

Or, Temperature evaluated at the different nodes / grids for various boundary conditions, where, m = column no., n = row no., q = heat generation rate, k = thermal conductivity, $T_{m,n}$ = temperature at (m,n) grid location, $\Delta x = \Delta y$ = grid width (say), T_w = fluid temperature, h = convection coefficient.

Typical heat load (due to surface heating) on the rotor is of 4 kW which is considered as even heat generation over the entire area.

CALCULATION

As the geometry is very complex, discretization leads to error.

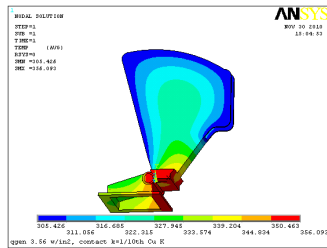

Figure 3: Housing flange without contact, @ 4 kW

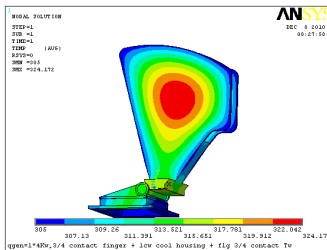

Figure 4: Flange & Housing 3/4th contact finger, @ 4 kW

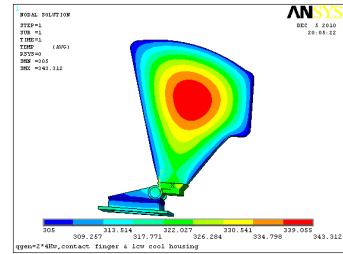

Figure 5: Flange in adiabatic, Housing in full contact finger conditions @8 kW

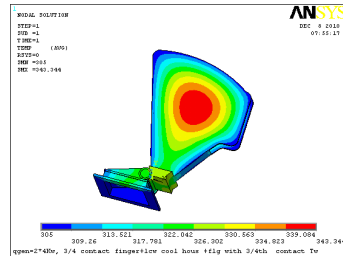

Figure 6: Flange with 3/4th contact, Housing 3/4th contact finger, @8 kW

Microsoft Office Excel based iterative calculation with a FDM method approach is too crude to this sort of calculation. The FEM analysis on this complex structure gives the realistic evaluation. A steady state 3-D thermal analysis over ANSYS Multiphysics platform gives a very comparable result. The summarized result (@4 kW & 8 kW) is shown in Fig.3 to Fig.6. For, 10 lpm LCW flow rate, v founds to be 7.81 m/s i.e. $Re = 4.71 \times 10^4$. Average LCW temperature is 305 K, h at LCW boundary = 25100 w/m^2 K, h at natural air cool boundary = 25 w/m^2 K, whereas, Housing temperature is assumed at ambient temperature of 305 K. The maximum hotspot temperature varies from 324 K to 343 K (i.e. 51^o C to 70^o C) depending upon heat load.

CONCLUSIONS

Improper Contact or adiabatic face of the housing may raise the temperature and change hotspot location. The overall heat load due to RF is of great concerns although the contact finger (Be-Cu) takes role in temperature distribution. The system is running smoothly with modified contact fingers without any appreciable temperature rise which was observed earlier even at 60 MeV alpha beam.

ACKNOWLEDGEMENT

The author thanks to the co-authors for their various co-operation and advice.

REFERENCES

- [1] "Fundamentals of Mass and Heat Transfer" by Frank P Incropera, David P DeWitt,
- [2] ANSYS Multiphysics Manual- Release 10.0,
- [3] "Numerical Methods for Engineers" 4th Edition, by Steven C Chapra, Raymond P Canale.