

### **3. RESEARCH SUPPORT FACILITIES**

#### **3.1 HIGH VACUUM LABORATORY**

M. Archunan, A.Kothari, P.Barua, A. Mandal

Installation of new LEIBF facility is in progress. Switching magnet has been placed and beamlines are marked on the floor. Regular involvement with the Pelletron group regarding maintenance activity (scheduled and emergency), vacuum operations, maintenance of vacuum pumps and installation of critical components is going on.

##### **3.1.1 Installation of new LEIBF Facility**

Installation of New LEIBF facility is in progress, in the new material science building. Beamline height has been decided to be kept at 1.75 m. Magnet position has been fixed and placed accordingly. All the beamlines have been marked on the floor and beam height references have been marked on the wall. Mild steel plates are embedded on the floor along the beamlines, for fixing of beamline stands. Design and fabrication of beamline stands is over. The remaining installation activity is in progress.

##### **3.1.2 Installation of New Gas Cell Absorber in AMS Set-up**

A new Gas Cell Absorber was installed in the AMS set-up by removing the previously installed Gas Cell. Proper modification for the support and flange of the gas cell was suggested for removing the errors in fabrication. Finally the Gas cell and Gas detector were installed and properly aligned.

##### **3.1.3 Installation of Raman Chamber in Materials Science Phase II Beam Line**

A new chamber called Raman Chamber was installed and aligned with the beam axis in material science phase-II beamline. It was then integrated with the existing beamline by adding required drift tubes and bellows at the entry and exit of the chamber. One linear Z-Z motion unit was installed on the lid of the chamber and one rotary unit was mounted on the linear motion unit with an I piece. Target ladder of the chamber was also aligned with beam axis. Full vacuum system i.e. pumps, vacuum valves, gauges and interlock controller were installed and commissioned. Entire area was leak checked before handing over the system for experiment.

##### **3.1.4 Installation of Electrostatic Analyzer in Phase II Atomic Physics Line**

An Electrostatic Analyzer was installed in the atomic physics phase-II beamline after the main chamber. The functional plates inside the unit were not accurately in place with the

ports. So the plates position inside the chamber was rectified and alignment of the unit was done with respect to the plates position. A trapezoidal detector chamber was also installed and aligned. Two X-X slits were installed just before the analyzer and zero calibration was done for all the slits. Malfunctioning of the slit was also detected and rectified. An insertable faraday cup was also installed and aligned.

### **3.1.5 Local Controller for Double Slit for ECR Beam Line**

The Actual NEC Double slit controller can be operated only by CAMAC. Hence, one controller has been fabricated for operating the Double slit without a CAMAC. This controller is used to control all the four Jaws +X, -X, +Y and -Y positions by varying a 10 turn Pot independently. It has the following options for each Jaw,

- Start Button : To Start the movement
- Set position : To set position
- SR Position : Position Read Back
- SR CUR : Current Read Back

### **3.1.6 Design and Development of Electronic Modules for New LEIBF**

Design and development of electronic modules for controlling Faraday Cup, Beamline Valve Controller and Interfacing cards is in progress. All these cards will be modular based taking minimum space and for replacement. Diagnostics is made very simple and all the important Status Read backs are displayed in the front panel as well as in the remote place through the Indigenous Control System. Circuit design for all the modules is over and PCB designing is under process. PCB's for interfacing cards for Control System & Device have been designed and design is based on our Indigenous Control System developments. There will be three Interface cards which are:-

- One PCB for Interfacing the Input Gate and Output Register Module with Control System.
- One PCB for Interfacing the ADC Module with Control System.
- One PCB for DAC Module with Control System.

### **3.1.7 Modification and Installation in Ion Source Test Bench**

During installation it was detected that entry and exit port height of the magnet was mismatch by 3mm. Also the alignment of GP tube and ion source was not proper. Due to these factors the user was facing problem in getting proper beam. These problems were rectified by

dismantling the system and realigning each component. Two theodolites were set up at entry and exit port of magnet to rectify mismatch. Further following actions were taken:

- All components from source to magnet were dismantled, reinstalled and aligned.
- Einzel Lens assembly and source were removed and realigned with the magnet.
- An additional bellow was installed for independent alignment of GP tube.
- A quadrupole doublet was installed and aligned.
- The entire beamline was raised by 3mm to match magnet height.
- All components and target ladder aligned and calibration of double slit done.
- Due to lack of space beam line valve BLV moved from magnet entry side to magnet exit side.
- Ion Source Test Bench completely aligned from Source to Experimental chamber.

### **3.2 MAINTENANCE AND SERVICING OF POWER SUPPLIES AND MAGNETS**

S.K.Suman, Rajesh Kumar, Mukesh Kumar, A.J.Malayadri, A.Mandal

Beam transport group is primarily involved in maintenance & servicing of different types of power supplies, magnets of various facilities like Beam Transport System of Accelerator, Target lab's vacuum deposition unit power supplies and detector power supplies to ensure trouble free round the clock operation with maximum uptime.

#### **3.2.1 Beam Transport System Maintenance**

BTS group takes care of instruments like magnets, their power supplies and other supporting instruments viz. CAMAC Modules, magnetic field measuring instruments, beamline selector switchgear etc of the accelerator systems. For smooth and round the clock running of all these instruments, we have done preventive as well as breakdown maintenance as mentioned below :

**Scheduled maintenance:** Schedule maintenance of magnet power supplies, magnets and magnetic field measuring instruments has been done carefully and thoroughly twice this year to minimize breakdown /failure during beam time. Following scheduled tasks are carried out during preventive scheduled maintenance:

- Output ripple monitoring of all power supplies and rectification.
- Stability measurement and rectification magnet power supplies.
- Safety interlock testing.

- Calibration of control electronics.
- Functional testing of CAMAC modules for remote operation of magnet power supplies.
- Thorough observation of all power devices like power contactors, power transistors and water cooled heatsinks etc and changing the faulty ones.
- Dust cleaning from electronic cards and power supplies.
- Checking the connections for control signals in all power supplies.
- Checking the power connections for loose contacts.
- Checking water leakage in the cooling systems and changing damaged hose pipes.
- Temperature monitoring of water cooled components like magnet's coil and transistor bank heatsinks to check the cooling efficiency at full load and cleaning the partially blocked coils.

**Breakdown Maintenance:** This year there was only one major breakdown in MQX-LX1 power supply ( transistor fails, took 5hrs. for repairing). Although small problems were also encountered like power supply tripping because line voltage glitches, water failure and remote control latching which were attended whenever reported.

### 3.2.2 Target Development Lab power supplies

Following High vacuum deposition units power supplies are used Target lab. All these were serviced whenever the problem occurred.

- 6kW-Electron beam source power supply (6kV, 1A)
- Electron XY sweep controller
- 2kW-Electron beam source power supply (4kV,0.5A)
- Fast Atom beam source power supply (100mA,3kV)

### 3.2.3 Detector bias High Voltage power supplies

Following Detector bias high voltage power supplies were maintained whenever breakdown reported.

- Germanium detector bias supply (5kV,100uA)
- ACS Detector bias power supply (3kV, 10mA)
- Preamplifier power supply ( $\pm 24V, 1A \pm 12V 1A$ )

### 3.3 DETECTOR LABORATORY

A. Jhingan, P. Sugathan

Detector Laboratory at IUAC provides experimental support to users in setting up charged particle detectors and readout electronics. New detectors and electronics have been designed and developed for the upcoming experimental facilities. Apart from various developmental activities, the group is intensively involved in various user experiments in nuclear reaction dynamics in HIRA, GPSC and Neutron Array using heavy ion beams. Detector lab provides training on experiential activities for Scientist Trainees, JRF students, and M.Sc orientation program students.

#### 3.3.1 Charged particle detector array for INGA

A. Jhingan, P. Sugathan, J. Zacharia, R. K. Bhowmik

A charged particle detector array is planned for the future INGA campaigns. Currently the focus is on building a CsI array for the detection of protons and alphas produced in a nuclear reaction. A prototype spherical hollow chamber (~10" diameter) has been fabricated (Fig.1) for mounting the detector system. The chamber is built using three parts comprising two hemispheres and one central cylinder. The whole body was machined from a solid aluminum cylinder using the CNC lathe and milling machine at the IUAC mechanical workshop. It has a wall thickness of about 3mm to avoid gamma attenuation and scattering.



**Fig.1: Spherical Aluminum chamber**

CsI detectors of 3 mm thickness with an active area 20 mm x 20 mm coupled to a 10 mm x 10 mm photo-diode were acquired from Scionix, Holland. This design of the detector was preferred to make it compatible with the proposed TIFR charged particle array. The detector was mounted inside the spherical chamber and tested with an in-house fabricated preamplifier. The preamplifier has a gain of 2V/pc (Si equivalent) with a power consumption of < 50mW. The detector was tested with various radioactive sources to check its performance. Off line protons were generated using Am-Be neutron source and polypropylene foil. The recoiling protons from the foil were detected along with alphas from <sup>241</sup>Am and gammas. The 2D plot generated using ballistic deficit technique shown in fig.2 shows clean separation between the different particles. Efforts are on to develop custom made front end electronics and acquire more detectors. A beam test is being planned with developed chamber and detector in beam hall II in future.

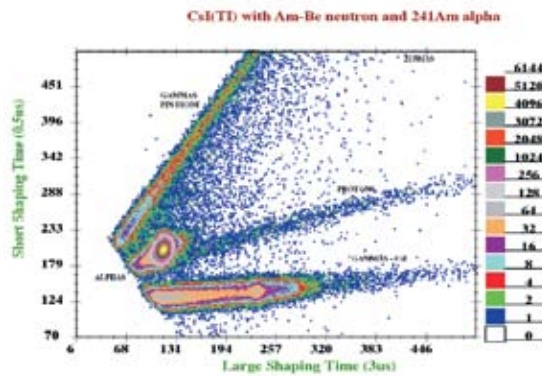

**Fig.2: PSD spectra showing separated bands of gamma, protons and alpha**

### 3.3.2 Fast timing MWPC

A fast timing MWPC (transmission type) of active area 1.5” x 1.5” was developed last year. The detector is intended to be used for time of flight applications in NAND and GPSC experiments, providing the master start signal for time of flight measurements of fission detectors and neutron detectors in experiments to be performed with DC beams from Pelletron. It was recently used in an experiment to study the fission fragment mass distribution for the system <sup>6,7</sup>Li + <sup>238</sup>U in GPSC. The experiment was performed using DC beam from Pelletron. One arm of the GPSC had the fast MWPC placed 7.5cm from the target followed by large area position sensitive MWPC at a distance of 40cm. The other arm had one large area position sensitive MWPC at a distance 50cm from the target. The fast MWPC provided master trigger for all timing signals such as TOF and position signals of MWPC. To avoid straggling, the entrance and exit foils of fast MWPC were replaced by a 0.5 micron mylar foil. In future we plan to put another fast MWPC on other arm of GPSC so that both arms have independent TOF systems. This not only enables us to perform experiments with DC beams but also provides nearly absolute timing of heavy ions.

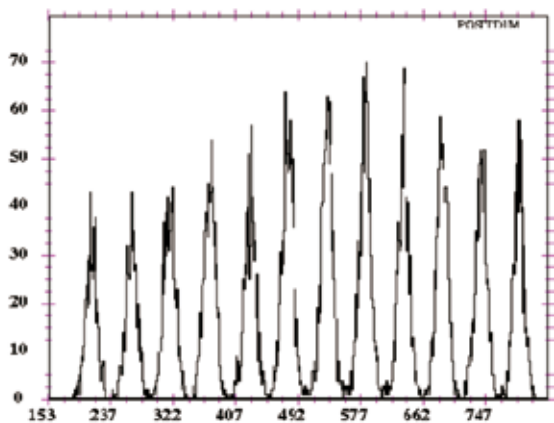

**Fig. 3. Masked position spectrum from one of the resistive strip**

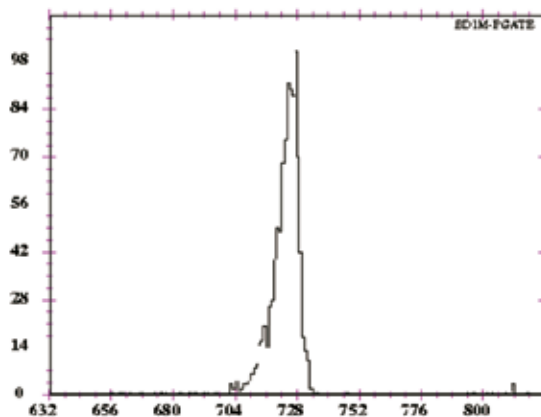

**Fig. 4. Position gated energy spectra of  $^{241}\text{Am}$  alpha.**

### 3.3.3 Testing of Silicon Strip Detector with resistive strips

A silicon strip detector from Micron Semiconductors (UK), design X was tested using Mesytec pre-amplifiers and amplifier combination. This detector has 16 strips which are resistive. Such a detector has a smaller dead region at entrance (few hundreds of nanometers) making it ideal for the detection of low velocity heavy ions (.03 MeV/A in mass 200 region). The detector was tested with alpha  $^{241}\text{Am}$  source. Series termination resistors were used to minimize ballistic deficit in the resistive strips where energy is a function of position. Fig.3 shows the masked position spectrum from  $^{241}\text{Am}$  alpha. The mask had 1 mm holes at 4 mm separation. The position resolution is  $\sim 1$  mm. The raw energy resolution obtained, by summing position signals on both ends of a resistive strip, was  $\sim 75$  keV. On putting position gates, the energy resolution obtained was 52 keV as shown in fig.4. Further tests will be carried out to improve the position and energy resolutions. We would like to acknowledge Dr. Subinit Roy (SINP) for providing us the silicon detector for testing.

### 3.3.4 Detector system for transfer studies in GPSC

A. Jhingan, P. Sugathan, Sunil Kalkal (DU), R. Ahuja

A new detector setup comprising of two position sensitive MWPC and an ionization chamber is currently under fabrication. The detector setup has been designed to study transfer reactions in GPSC. One MWPC will be placed in forward angle to detect target like particles and the other MWPC followed by an ionization counter will be placed at backward angle to detect projectile like particles. The detectors will be placed at kinematic coincident angles to detect both target like and projectile like particles simultaneously. The MWPC will give time of flight as well as position (for angular distribution) and IC will give the Z identification and total energy. Both the MWPCs have an active area of 5cm x 5cm, and IC has an active area of

8cm x 4.5cm with an active depth of 21cm. A split anode geometry with 4 segments has been used in IC.

### 3.3.5 Silicon strip detector readout using MANAS chip

A. Jhingan, P. Sugathan, Kundan Singh, B.P. Ajith Kumar

We have tested the performance of the MANAS chip [1] for processing signals from a silicon strip detector irradiated with alpha particles from radioactive source. The MANAS chip developed by SINP, Kolkatta consists of 16 input channels and one output. Each channel has a charge sensitive pre-amplifier, a semi-Gaussian shaper and a track and hold stage. An analog multiplexer converts the 16 parallel inputs into one serial output. To readout the MANAS chip a home made VME based ADC module has been used which converts the multiplexed output into digital value that are acquired using the VME bus interface. The performance was tested using a 16 channel double sided silicon strip detector (DSSD) connected to the inputs of MANAS and collecting the signals induced by alpha particles from a mixed radioactive source (Am-Pu). All the 16 strips on the front side were connected to MANAS inputs. The trigger was generated from the back side of the detector. Energy and position information of the particles stopped in the silicon detector were extracted. Figure 5 and 6 shows the schematic of the test setup and the 1D histogram showing energy spectrum from one of the strips (#2) respectively. The two peaks correspond to two energies of the alpha particles from the source. We thank Prof S. Chattopadhyay (SINP) for providing us the MANAS chip.

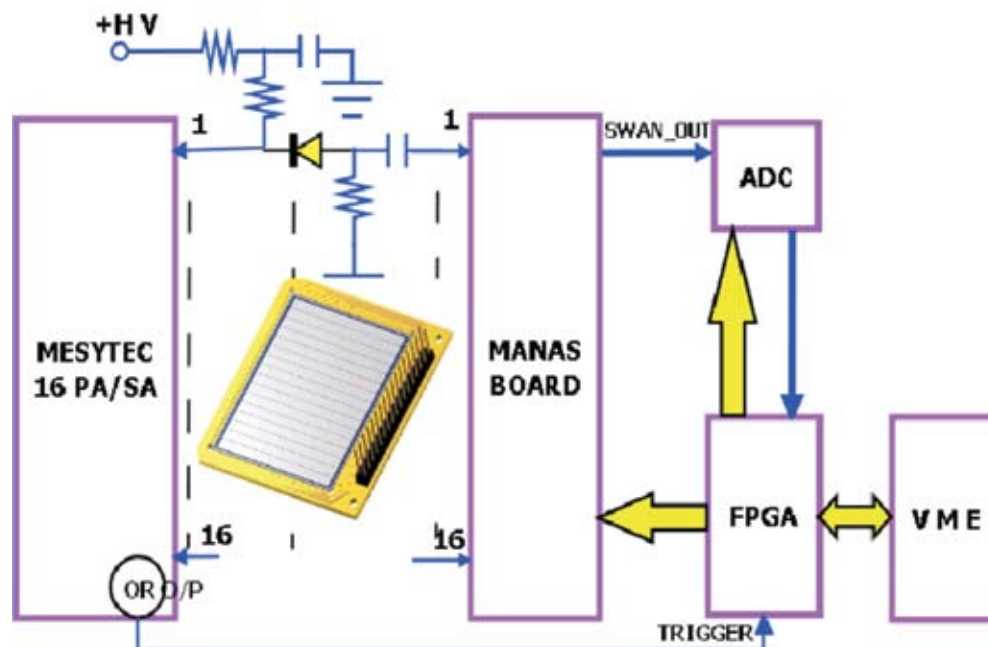
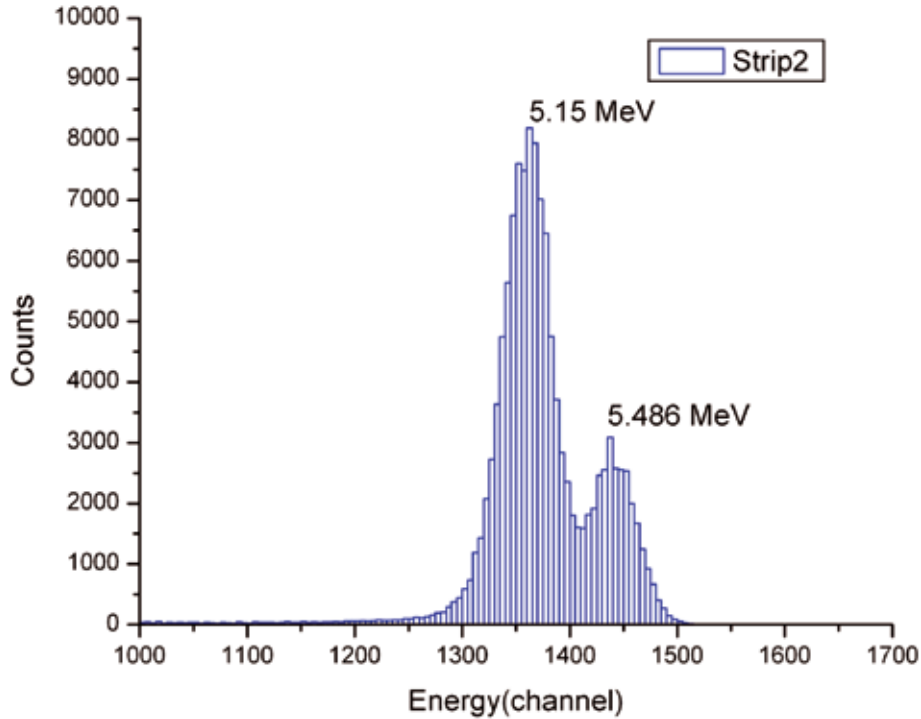

Fig. 5. DSSD readout scheme using MANAS.





**Fig. 6. Alpha particle energy spectrum from Am-Pu source**

## REFERENCE

- [1] P. Bhattacharya et al, DASE Symp. on Nucl. Phys. 45B(2002)484.

## 3.4 TARGET DEVELOPMENT LABORATORY

D. Kabiraj, Abhilash S. R and D. K. Avasthi.

Target Development Laboratory at IUAC provides facilities to the users for the preparation of targets used for the experiments with IUAC Pelletron and LEIBF facilities. Several users have used the following facilities for the studies in Nuclear Physics, Atomic Physics, Materials Science and Bio Science: (i) a high vacuum evaporator, equipped with 2kW electron beam gun, evaporation setup by resistive heating, online thickness monitoring by quartz crystal thickness monitor. This evaporator is pumped by a diffusion pump with liquid nitrogen trap, with a base pressure of high  $5 \times 10^{-7}$  mbar. (ii) The oil free pumping system for the second evaporator includes a cryo-pump, a turbo molecular pump and a scroll pump, with a base pressure of  $6 \times 10^{-9}$  mbar. This evaporator is equipped with a 6 kW 4-pocket electron gun and evaporation setup by resistive heating method and a dual crystal thickness monitor and controller for online thickness monitoring and process control. (iii) A rolling machine for the preparation of thin foils by cold rolling method. (iv) A facility with wide atom beam

source (ABS) has been used for the fabrication of composite thin films by sputtering method, making surface structuring on single crystal and amorphous materials.

The atom beam source has been used extensively for last few years to produce composite thin films with very interesting functionality [1-7]. Recently amorphous carbon and Pd have been co-sputtered to form composite thin films [8]. Samples containing Pd nanoparticles dispersed in insulating carbon matrix were irradiated with 120 MeV Au ion beam at fluence of  $5 \times 10^{13}$  ions/cm<sup>2</sup>. Magnetic properties of the Pd nanoparticles have been investigated. Structural investigations along with superconducting quantum interface device measurements show that ferromagnetic properties of the Pd nanoparticles are due to the deviation of their electronic structure from that of bulk. The electronic structure is further modified due to the creation of defects on ion irradiation, which results in 20 times increase in the saturation magnetization. The present study establishes that the defect induced modification of Pd 4d electronic structure is responsible for the ferromagnetic properties of the Pd nanoparticles.

Realizing the utility of energetic atom beam, Inductively Coupled Plasma (ICP) source with electron source for active neutralization has been purchased using DST Nano-mission grant. The source produces very low energy *neutral* beam (Ar, N, O) with energy between 400 to 1000 eV and current 20 mA - 75 mA. Initial testing of the source has been performed successfully. Figure 1 shows the Ar beam produced from this source.

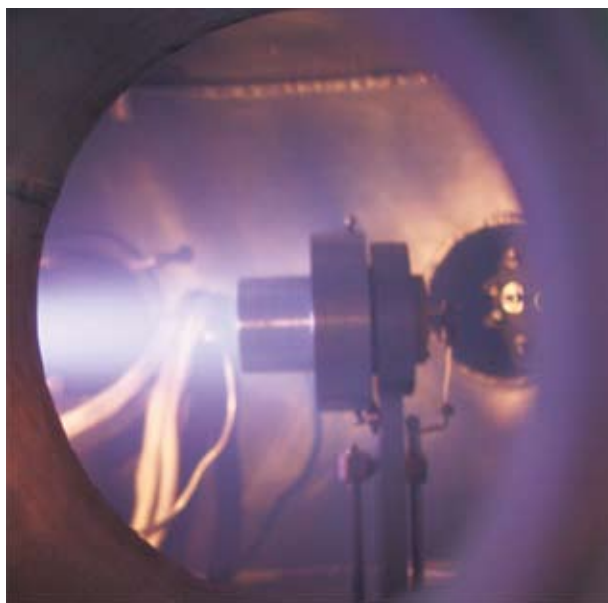

**Fig. 1. Ar beam produced**

This laboratory prepares isotopically enriched targets for the users related to nuclear physics and atomic physics experiments [12-14]. The isotopic targets prepared in this year are <sup>116</sup>Sn, <sup>118</sup>Sn, <sup>122</sup>Sn, <sup>124</sup>Sn [15], <sup>180</sup>Er. The Sn targets were prepared both by

cold rolling of metal foils and vacuum evaporation technique. The targets of thickness 0.2-0.6 mg/cm<sup>2</sup> were prepared by thermal heating in vacuum evaporator. A special kind of boat made of Tantalum was used to minimize the loss of metal by restricting the vapour in a narrow solid angle. Sn targets of thickness >1.2mg/cm<sup>2</sup> were prepared by cold rolling technique. Pair of polished stainless steel sheets was used for this purpose. The metal tends to stick to the plates when the thickness reaches ~5 mg/cm<sup>2</sup>. For further reduction of thickness, the Sn foils were carefully shifted into a folder of Teflon sheet. The minimum thickness of Sn foils achieved by using Teflon sheets was 1.2 mg/cm<sup>2</sup>. Preparation of <sup>180</sup>Er target of thickness 200 µg/cm<sup>2</sup> on carbon backing of thickness 30 µg/cm<sup>2</sup> and capping layer of 40 µg/cm<sup>2</sup> was very complicated. The Er films deposited on carbon backing produce so much of strain that the foil gets ruptured. To overcome this different methods were tried like post growth annealing, substrate heating. After several attempt and fine tuning the growth conditions like substrate temperature, deposition rate, carbon backing foil, Er and carbon cap layer thickness using natural Er metal, the desired target could be made. Only 100 mg of <sup>180</sup>Er was available in the stock, which was enough for single evaporation. So extreme care was taken when working with <sup>180</sup>Er. Previous evaporation conditions were adopted during the preparation of <sup>180</sup>Er target and finally desired target could be prepared successfully.

## REFERENCES

- [1] 'Embedded SiGe nanoparticles formed by atom beam co-sputtering of Si, Ge, SiO<sub>2</sub>,' Kapil U. Joshi, D. Kabiraj, A.M. Narsale, D.K. Avasthi, T.N. Warang and D.C. Kothari. Surface and Coatings Technology 203 (17), p.2482-2485, 2009.
- [2] 'Synthesis of Plasmonic Nanocomposites for Diverse Applications.' D. K. Avasthi, Y. K. Mishra, R. Singhal, D. Kabiraj, S. Mohapatra, B. Mohanta, Nivedita K. Gohil, and N. Singh. Journal of Nanoscience and Nanotechnology Vol.9, 1-7, 2009.
- [3] 'Effect of rapid thermal annealing on Si rich SiO<sub>2</sub> films prepared using atom beam sputtering technique.' Trupti N. Warang, D. Kabiraj, D.K. Avasthi, K.P. Jain, K.U. Joshi, A.M. Narsale and D.C. Kothari. Surface and Coatings Technology 203 (17), p. 2506-2509, Jun 2009.
- [4] 'Controlled growth of gold nanoparticles induced by ion irradiation: An in situ x-ray diffraction study.' Y. K. Mishra, D. K. Avasthi, P. K. Kulriya, F. Singh, D. Kabiraj, A. Tripathi, J. C. Pivin, Appl. Phys. Lett. 90, 073110 (2007).
- [5] 'Synthesis and Characterization of Ni Doped ZnO: A Transparent Magnetic Semiconductor' B. Pandeya, S. Ghosha, P. Srivastavaa, D. K. Avasthi, D. Kabiraj, J. C. Pivin. Journal of Magnetism and Magnetic Materials (2008).
- [6] 'Synthesis of Au nanoparticles in partially oxidized Si matrix by atom beam sputtering' S. Mohapatra, Y. K. Mishra, D. K. Avasthi, D. Kabiraj, J. Ghatak and S. Verma, J. of Phys. D: Appl. Phys. 40 (2008) 7063.
- [7] 'Synthesis of gold-silicon core-shell nanoparticles with tunable localized surface plasmon resonance.' S. Mohapatra, Y. K. Mishra, D. K. Avasthi, D. Kabiraj, J. Ghatak, S. Varma. Appl. Phys. Lett. 92, 103105 (2008).

- [8] ‘Synthesis of metal–polymer nanocomposite for optical applications.’ DK Avasthi, Y K Mishra, DKabiraj, N P Lalla, J C Pivin, *Nanotechnology* 18 (2007).
- [9] ‘Synthesis and characterization of Ag nanoparticles in silica matrix by atom beam sputtering.’ Y.K. Mishra, S. Mohapatra, D. Kabiraj, B. Mohanta, N.P. Lalla, J.C. Pivinc, D.K. Avasthi, *Scripta Materialia* 56 (2007) 629–632.
- [10] ‘Gold–silica nanocomposites for the detection of human ovarian cancer cells: a preliminary study.’ Y KMishra, S Mohapatra, DK Avasthi, D. Kabiraj, N P Lalla, J C Pivin, Himani Sharma, Rajarshi Kar, Neeta Singh, *Nanotechnology* 18 (2007) 345606.
- [11] ‘Enhancement of ferromagnetism in Pd nanoparticle by swift heavy ion irradiation.’ P. K. Kulriya, B. R. Mehta, D. K. Avasthi, D. C. Agarwal, P. Thakur, N. B. Brookes, A. K. Chawla, and R. Chandra, *Appl. Phys. Lett.* 96, 053103 (2010).
- [12] ‘Conversion of  $160\text{Gd}_2\text{O}_3$  to  $160\text{Gd}$  by vacuum reduction-distillation.’ V. Kumar, S.R.Abhilash, D.Kabiraj, P.Thakur, A.K.Bhati. *Nucl. Instr. Meth. A*, 613, 401 (2010).
- [13] ‘Preparation and preservation of praseodymium targets at IUAC.’ V. Kumar, S.R. Abhilash, D. Kabiraj, P. Thakur, A.K. Bhati. *Nucl. Instr. Meth. A* 613, 404 (2010).
- [14] ‘Fabrication of  $^{90,94}\text{Zr}$  targets on carbon backing’ Sunil Kalkal, S.R.Abhilash, D.Kabiraj, S.Mandal, N.Madhavan, R.Singh. *Nucl. Instr. Meth. A* 613 (2010) 190.
- [15] ‘Isotopic Sn target fabrication at IUAC.’ A. Singh, A. Shukla, D. Singh, Abhilash. S. R, D. Kabiraj, D. K. Avasthi. *International Symposium on Nuclear Physics Dec. 2009 Mumbai*.

### 3.4.1 Characterization of nc-Ge prepared by ABS and RTA

N Srinivasa Rao<sup>1</sup>, N Sathish<sup>1</sup>, G Devaraju<sup>1</sup>, V Saikiran<sup>1</sup>, A P Pathak<sup>1</sup>, D Kabiraj<sup>2</sup>, D C Agarwal<sup>2</sup>, P K Kulriya<sup>2</sup> and D K Avasthi

<sup>1</sup>School of Physics, University of Hyderabad, Central University, Hyderabad

<sup>2</sup>Inter University Accelerator Centre, New Delhi

Si and Ge nanocrystals embedded in  $\text{SiO}_2$  matrix have recently attracted much attention due to their possible applications in optoelectronics. Here we report the structure of the Ge nanocrystals formed by Rapid Thermal Annealing (RTA).

The samples were prepared by fast Atom Beam Sputtering (ABS) method by keeping Ge concentration as 32% by co-sputtering of Ge and Silica using 1.5 keV Ar atoms. The RTA was carried out at 700°C and 800°C for 60s in  $\text{N}_2$  atmosphere (2000 SCCM). Eventually these films were characterized by Raman and X-ray diffraction.

The Rutherford Backscattering Spectrum of the  $\text{Ge}+\text{SiO}_2$  composite pristine sample has been shown in Fig.1 (a). The estimated Ge concentration in this film was about 32%. The thickness of the composite films is around 140 nm.

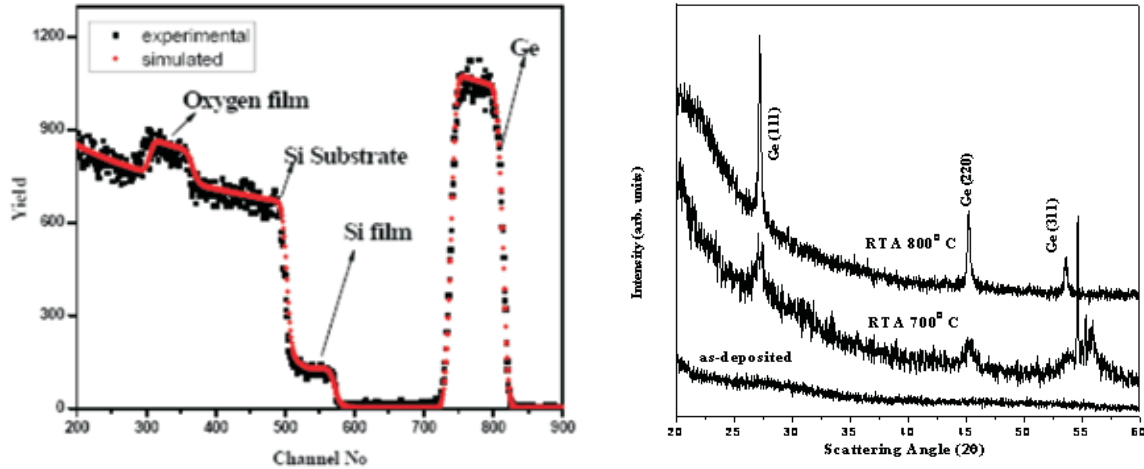

**Fig.1: (a) RBS spectra of Ge 32% as-deposited sample and (b) XRD spectra of Ge 32% as-deposited and annealed samples.**

The X-ray diffraction (XRD) spectra of the as-deposited and rapid thermal annealed samples are shown in Figure.1 (b). For as-deposited sample, no peak is observed, whereas the annealed samples at temperatures 700°C and 800°C show three obvious peaks of Ge (111), (220) and (311) planes, which indicates the formation of nc-Ge. Results are being analyzed.

### 3.5 RF & ELECTRONICS LABORATORY

A. Sarkar, S. Venkataramanan, B.K. Sahu, K. Singh, A. Gupta, A. Pandey, P. Singh & B.P. Ajith kumar

#### 3.5.1 INGA-LEPS Electronics module

A double width NIM module containing Shaping amplifiers, Timing Filter Amplifier (TFA), Constant Fraction Discriminators (CFD) and logic circuitry has been developed for processing signals from a LEPS (Low Energy Photon Spectrometer) detector with optional Anti Compton Shield (ACS). The present module is essentially a modified version of Clover electronics module of INGA, wherein the main shaping amplifier and Timing Filter Amplifier gain are altered for LEPS detector. The module is tested with LEPS detector at VECC, Kolkata and typical results obtained are given below. 8 numbers of this module is assembled, tested and delivered to INGA (Resolution: 0.860 KeV at 121 keV, 0.938 KeV at 244 keV with <sup>252</sup>Eu at 3Kcps).

### **3.5.2 Status of various electronics for NAND array at IUAC**

#### ***Pulse shape discriminator module***

An improved version of existing pulse shape discriminator (PSD) module with added features for upcoming NAND at IUAC has been wired and being tested. The features added are compact shaping amplifier with baseline correction, semi-gaussian unipolar output, n or n-g spectrum selection with switch, LED blinking and adoption of low power ECL monostable multi vibrator chips instead of power hungry MC10198P chip.

#### ***Auxiliary Power supply***

In order to conserve space for front end electronics in a large array such as NAND, efforts are made to accommodate as many as 10 such modules in a standard 200 watts NIM crate, with additional power supplies. Since reported last year, we have built two such power supplies each of -6V, 20A to accommodate entire PSD electronics for 30 detectors in two NIM crates.

#### ***Technology transfer***

Due to large scale requirement of PSD modules for various pulse shape discrimination applications in the country, a memorandum of understanding (MOU) has been signed between IUAC and M/s. ECIL, Hyderabad for technology transfer of PSD electronics module for commercial production. The complete technical documentation of various sub-systems involved have been prepared and transferred. The prototypes being developed at M/s. ECIL are expected to be delivered to IUAC for evaluation during July 2010.

#### ***Fission detector electronics***

The primary motive behind National Array of Neutron Detector (NAND) at IUAC is to study the reaction dynamics in fusion fission reactions in the low/medium energy region. The detection of neutron in coincidence with fission fragments is essential in these types of studies. The large area position sensitive Multi Wire Proportional Counters (MWPC) developed at our center [1] have been proved to be excellent for fission fragment mass and angular distribution studies [2]. The fission detector electronics for 5 electrode geometry requires various front end functional blocks as shown in figure.1. The functional blocks required are Shaping amplifier (Shaper) for energy signal, fast pre-amplifiers (FPA), timing filter amplifiers (TFA), constant fraction discriminators (CFD), gate and delay generators (GDG), logic units (CO). We have developed and demonstrated a single width NIM module, that contains most of the functional blocks shown in dotted box of Fig.1., avoids intensive cabling and numerous commercial modules such as shaping amplifiers, CFD, GDG etc.,



## REFERENCES

- [1] A. Jhingan, et.al., DAE-BRNS Symposium (2004), Varanasi.
- [2] Annual Report 2004-2005, Nuclear Science Centre, Section: 3.3, Page: 59-60.

### 3.5.3 VME based readout module for Analog multiplexed ASICs

New generation of experimental facilities comprises of detector arrays with several hundreds to thousands of independent detector segments. To process the signals from segmented detectors, specific ASICs (Application Specific integrated Chip) are now being commonly developed and deployed in large detector arrays. In many experiments, the number of signals (multiplicity) for a given event is small compared to the total number of detector segments, and consequently analog multiplexing is preferred for signal readout. Analog multiplexing has the advantage of reduced space, easier readout and it is cost effective. One such commonly used front end ASIC is the GASSIPLEX[1] developed at CERN and recently, a new variant of this called MANAS[2] has become available to high energy physics experiments. In this proceeding we report the development of readout electronics for processing and digitizing the MANAS signals for nuclear physics applications using silicon strip detectors.

We have designed a custom VME [3] 3U card to readout all the 16 strips of the silicon detector, which are the inputs to the MANAS chip. The design includes a VME bus slave interface, Interrupter module and dedicated MANAS chip controller. The core design of VME bus slave interface operates like a bridge between VME bus and the MANAS controller (designed on the same chip). As we know VME bus interface is asynchronous, meaning that any central clock does not coordinate the VME backplane signals. This can be a very difficult problem when interfacing to programmable chips like FPGA, which generally use synchronous design practices. It is necessary to synchronize all the signals, with system clock, from VME bus backplane before passing them to the MANAS controller. Our VME core design is an A24:D32:D16 interface, meaning that it participates in 24-bit addressing cycles and 32-bit (or smaller) data cycles. The core design of VME responds to VME bus single read and single write cycles. It also responds to the block transfer BLT16 and BLT32. The FPGA code is written as industry standard Hardware Description Language (VHDL). We have implemented our design on Xilinx's Spartan IIE FPGA. A process called synthesis converts the VHDL source code into machine instructions that the FPGA device understand. An overview of the readout boards is given in Fig 2.



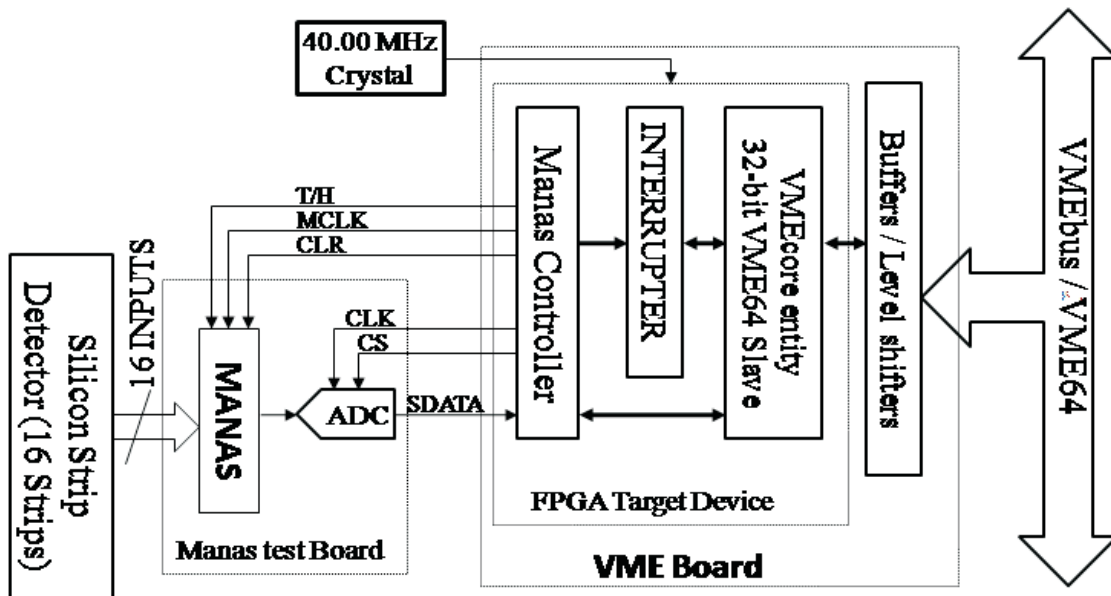

Fig. 2. Multi-harmonic buncher (MHB) for High Current Injector (HCI)

It has been decided to bunch the HCI beam before putting it through the RFQ for further acceleration. After several feasibility studies it was found that a multi-harmonic buncher is best suited for the job. The design of the multi-harmonic buncher is similar to the existing pre-tandem buncher. Only the power requirement is slightly less. The maximum bunching voltage is  $\sim 1\text{KVp}$ .

A set of new mechanical drawings are made for the entire buncher vacuum chamber and other associated parts. The list of different materials to be purchased is made. Ordering of materials are in progress. The fabrication of the vacuum chamber is going to start shortly. The fabrication of the different electronics modules are also being planned.

### 3.6 ELECTRICAL GROUP ACTIVITIES

U. G. Naik and Rajkumar

The main responsibility of Electrical group is to maintain the existing electrical installations and to take up the new challenges required for the up gradation of the institute's expansion of the experimental facilities. The uptime achieved for electrical systems was 100% without any breakdown/ shut down. This was possible with judicious maintenance schedules and monitoring arrangements. This group has also successfully completed the projects and works envisaged for the year F.Y.2009-2010.

## **MAINTENANCE:**

### **3.6.1 Captive Power Installations**

Institute has a Captive power base of 860 KVA. Group has managed the emergency power requirements with the available power generating sets and also has plans for bigger sets to meet the demand in future plans. The group has shown ever readiness in running the systems round the clock and within short notices smoothly.

### **3.6.2 Power Stabilisers**

The group has managed to have another year of 100% uptime without a single break in the supply through 1MVA and 500 KVA stabilizers catering to major loads such as A/C plant-II, Helium Compressors and the clean power to Pelletron cum experimental areas.

### **3.6.3 UPS Installations**

Electrical group with the help of various suppliers/ manufacturers has maintained 2X300KVA UPS, 4X60 KVA UPS, 1X50KVA UPS, dedicated to feed mixed loads of Helium Refrigeration System, High Current Injector systems and many other critical installations, besides a previous base of about 20 nos. of UPS rated from 2 kVA to 10 kVA. Only the 5KVA and above capacity UPS are put on AMC with respective manufacturers otherwise rest are all maintained by the group. During the present year all UPS were very healthy and had 100% uptime. Routine maintenance was carried out by the manufacturers' authorized service agents and the faulty batteries were replaced.

### **3.6.4 Power Factor Compensation**

Electrical group is very happy to report that average power factor of almost unity has been achieved throughout the entire year. Our system power factor without correction is about 0.85 and by raising it to near unity we save around Rs.45 lakhs a year from energy billing.

### **3.6.5 Wireless Communication Equipments:**

Electrical group maintains the hand held radio stations (Walkie-talkie) and base station used for round the clock security purposes. Till now we have 14 nos. of hand held stations and one base station. These are being maintained by us and the uptime during the year was 100%. The group takes the responsibility of getting the revalidation of license periodically from the Ministry of telecommunications.

### **3.6.6 Maintenance of Substation, Power and Lighting Installations of Office Complex and Residential Colony**

The electrical Group is proud to declare here that during this year the installations have performed efficiently with uptime close to 100%. Few of the major yearly maintenance activities carried out are listed as below.

- Dehydration of transformer oil.
- Periodic maintenance of LT panels, Distribution boards and other accessories, Lighting, Fixtures, lighting and power circuits.
- Servicing of DG sets 60kVAX2nos, 2X 320 kVA, 1X 100 kVA-twice a year.
- Maintenance of street lighting and earthing.

### **3.6.7 Energy Saving**

Energy savings measures taken earlier continued in the areas where we had installed the energy saving time switches and CFL lamps, T-5 lamps etc.

### **Project Works:**

#### **3.6.8 Installation for Beam Hall-II**

3ph. Powers to 5 more Quadrupole magnets of ratings of 300 amps capacity are provided in HYRA experimental area.

#### **3.6.9 Electrical System For 1.7 MV Pelletron**

Group carried out exhaustive study in consultation with Pelletronr group and framed the design specifications for the electrical part of the newly acquired 1.7 MV Accelerator coming up in Engineering building. It has been designed for 100% back up to continue the experiments even during power failures. The scheme involves 2X60 kVA UPS, 250 kVA DG Set, LT panels, Step down transformer, cable trays, dedicated earthing system for tank, ion source & experimental areas separately.

#### **3.6.10 11 kV Compact Outdoor Electric Sub Station**

Group has planned, designed, installed and commissioned a 1000 kVA outdoor type Compact unitized substation. The system includes HT vacuum circuit breakers in SF6 filled

steel tank, 1000 kVA, 11kV/433V transformer, multiple outgoings in LT panel with 300 kVAR capacitors automatically controlled. This substation will cater to BH-II (HYRA) and BH-III. It also has expansion capability to feed another substation/transformer for future loads.

### **3.6.11 AMS Lab Electrical Works With No Metal Parts Exposed**

Electrical works of power distribution & lighting have been completed for newly set-up AMS lab. Wooden cable tray is used for power distribution & resin transfer moulded type light fittings are used to avoid presence of any exposed metallic parts.

### **3.6.12 Electrical System for HPC Set Up**

The work of electrical system which comprise of following major components have been completed for HPC facility.

- 1600 Amp LT dual ACB input LT panel as main input panel
- 320+80 kVA redundant rack mount type UPS system
- UPS output panel
- Over head bus trunking system with dropouts for network racks
- Two independent copper earthing system.
- PLC controlled chillar control panel.

### **3.6.13 Residual Current ACB's for UPS Protection**

We have introduced residual current type Air Circuit Breakers for safety of 300 kVA UPS systems. These breakers have the capability of isolating the faulty system after observing the presence of residual current. Isolating the faulty system in initial stage helps to avoid any major failure of the connected equipment and hence saving time & money on repair.

### **3.6.14 Outdoor Surveillance System**

Electrical group is maintaining outdoor type CCTV surveillance system for security purposes. This year the system has been upgraded by introducing Infra Red LED type cameras capable to view in zero lux also during power failures etc. We have also introduced digital stand alone recorders for entry points.

### 3.6.15 Setup of 400 kV High Voltage Area for LEIBF

We have set up a high voltage platform of 400 kV rating in materials science building for LEIBF. The system is designed in Faraday cage configuration for safety reasons. The system involves 75 kVA, 400 kV isolation transformer, 12mA, 400 kV power supply & insulated platform. All safety features like door interlock, dedicated grounding system etc have been provided.

### 3.7 COMPRESSED AIR SYSTEM AND MATERIAL HANDLING EQUIPMENTS (MG I)

K.K. Soni and Bishamber Kumar

The group is associated with the following activities:

i) **Compressed Air System:** Compressed air plant ( Ph-I & PH-II ) consisting of two nos. reciprocating compressors each of 60 M<sup>3</sup> /Hr and two nos. screw compressors each of 115M<sup>3</sup>/Hr capacity, air dryers & filters with capacity of 3000 lpm @ 9.00 Kg/cm<sup>2</sup> have been maintaining uninterrupted air supply to tower, Beam Hall- I, Beam Hall -II and other associated lab areas round the clock. In order to further increase the reliability of the Compressed air supply at constant pressure, a 25 M<sup>3</sup> Storage tank is designed, fabricated and installed. It is installed in the Compressed air line on the roof of UB II. Pneumatic connections have been extended to all the labs.

A stand by screw compressor of 115 M<sup>3</sup>/Hr capacity is added in PH I plant in order to meet any eventuality of break down of existing compressor.

Further to ensure dew point of the air, the compressed air is passed through two refrigerated type air dryers of 4300 LPM capacity. Ultra high filters of boro silicate and carbon filters are provided in different location of the compressed air to provide clean air free from dust and oil particles. The filter cartridges of Ultra high filters are changed once a year to maintain the quality of supply air.

Since Reciprocating compressors which are more power consuming and source of excess oil contamination in the compressed air, therefore, the two reciprocating compressors are replaced by one Screw Air Compressor of 2208 lpm capacity. Compressed air piping has been extended to Lab I, Lab II and New Workshop building.

ii) **Industrial Gases:** Various industrial gases required in different labs have been made available from time to time. Special gases like Iso Butane and mixture gases are also procured for labs.

iii) **Elevator**: Elevator has been running smoothly and monthly preventive maintenance of the same is carried out to minimise the operational break down.

iv) **Material Handling System** : Periodic maintenance / servicing of more than 14 Nos E.O.T cranes and electric hoists of various capacity varying from 1 Tonne to 7.5 Tones are being carried out periodically and the same have been working smoothly. Two more cranes of 7.5 T capacities in BH III and 2 T Electrical Hoist in BH III has been added. All the cranes are put on remote control operation for safe handling of machines.

v) **Fire Extinguishers**: Annual refilling and periodic maintenance of all the fire extinguishers have been carried out. New fire extinguishers have been installed in newly constructed BH III, store area , Lab I and Lab II area, Workshop building. Some more sign boards including the “Escape route” is added in the building which shines even in darkness. .Demonstration for use of Fire extinguishers has been arranged and all the users and IUAC employees are trained to use the fire extinguishers.

New buildings under PH II part II have the newly added Fire safety norms which includes pressurised water hydrant system. It includes centralised pressurised water system connected to underground Water tank and water pumps which maintain continuous water pressure in the water hydrant line. This system is available in PH II Part II buildings.

### **3.8 AIR CONDITIONING, WATER SYSTEM AND COOLING EQUIPMENTS**

P. Gupta, A. J. Malyadri and Bishamber Kumar

#### ***AC System***

IUAC’s Central Air Conditioning / Low temperature Cooling System of Phase-1 consisting of 400 TR Central AC plant performed with 100% uptime. Proper maintenance ensured that the safety record of the plant was maintained at 100% and the power consumption kept at optimum levels. The reciprocating compressors (1,3&4) have logged in approximately 93,000 hours each and the new compressor#2 has logged 14,750 hours. Other rotary equipment except AHU#1-7 have logged in about 1,54,750 continuous run hours. The yearly maintenance costs have been maintained at approximately one-eighth the international standards of the installed project cost. Though, the plant has aged, yet the MTBF for all the equipment has shown a consistent rise over the years.

Five Nos. of AHU’s (AHU#1,2,4,5&6) were replaced by new ones. Two Nos. of 3.5 TR Split A/C’s have been installed in computer server room to take care of additional heat loads. The equipment being into their twenty-first year of sustained operations **have far outlived their economic lives**. In the current year, plenty of repair activities were carried out. This was essential to reset the reliability of the equipment.

The Phase-II, Central AC Plant with a Centrifugal Chiller and with its installed capacity of 250 TR performed to an uptime of 100%. The plant catered to EBW, UPS, Beamhall#II and cryogenic activities. The highlight of the operation and maintenance of the above systems was the in-house responsibility and supervision provided to the contracts, thereby affecting substantial savings in the price paid for the operation and maintenance contracts.

The Phase-III, Central AC Plant with a Screw Chiller and with its installed capacity of 250 TR performed to an uptime of 100%. The pending works on Engineering building Air-washers were carried out by IUAC departmentally as CPWD expressed their inability to do the same.

Ph-II & Ph-III Chilled Water Hook-up piping was installed and successfully commissioned in November 2009. This will enable us to take both the loads on either of the plants in the event of non-availability of minimum loads in any of the plants. Ph-3 A/C plant is running for both Ph-II & Ph-III loads since December 2009 and there-by effecting huge energy savings.

### ***Water System***

IUAC's centralized water system of Phase-I feeding low temperature cooling water of a total heat removal capacity of 115 TR, potable water supply and the gardening water supply performed to an operational uptime of 100%. This was possible due to the stringent maintenance practices that were followed over the years. The mechanical systems have already overshot 1,07,000 hours **beyond their expected life span**. A strict monitoring on the water quality ensured that the flow paths are in healthy condition. Numerous repair works were carried out.

The SS branch pipes in ISR, El. 256, Vault, Beamhall#I & II were extended close to the equipments. It helped us in reducing the length of flexible hoses to avoid frequent water leaks and reduced friction head.

IUAC's centralized water system of Phase-II feeding low temperature cooling water of a total heat removal capacity of 80 TR, Liquid Helium Cooling water of approx. 350 TR, potable water supply performed to an uptime of 100%.

IUAC's centralized water system of Phase-III feeding low temperature cooling water of a total heat removal capacity of 80 TR and potable water supply performed to an uptime of 100%.

### ***Cooling Equipment***

Availability of equipment was recorded at around 99%.

### ***New Works / Projects***

Beamhall#III Process Water System installation works have been successfully completed. The system had been commissioned without heat load and flow testing since the downside equipment is not put in place. The system was formally taken over from CPWD.

Beamhall#III low side air-conditioning installation work has been started by CPWD in February 2010 after a lot of persuasion from our end and after a lot of delay. It is expected to be completed in a few months' time. However, MG#2 had completed the high side works on the same long before, much ahead of schedule.

Rack cooling system has been installed for IUAC data centre server cooling. 4 nos. (3 working+1 redundant) of 33 TR each Air-cooled scroll chillers were installed to dissipate the total heat of 320 KW in 16 nos. of server racks. All the components in the system like pumps, pipes, valves etc., are in SS construction for long lasting and to prevent rusting in the system. Now the commissioning works are in the final stage.

Air-Conditioning works for AMS laboratory (clean room class 10000) were installed and is now ready for commissioning

### **3.9 CIVIL WORKS**

M.K.Gupta

#### **Works under Civil Section**

- Major expansion Projects ( right now Auditorium and Main Lab. Building vertical extension)
- Minor Projects
- Minor Works (additions, alterations, renovation in the existing Civil works)
- Civil Maintenance
- External Cleaning of the Campus
- Liasion with various Govt. and external agencies for statutory approvals and various civic problems

#### **Important Civil Activities during the Year 2009-10**

Following important Civil works were undertaken during the year 2009-10 in addition to routine Civil maintenance and minor works:



- Appointment of Consultant (M/S RITES) for new projects of construction of Auditorium and main Lab. building vertical extension and preconstruction planning
- Civil works for establishment of High voltage area in LEIB building
- Construction of open parking near Sumeru-III by concrete paving
- Resurfacing & repairing of IUAC campus roads
- Construction of open 'Stage' in IUAC playground near Phase II housing complex
- Civil works for establishment of AMS Lab. on E-side of Main building
- Supply of 13 no. sitting benches for IUAC open lawns and parks
- Fabrication and supply of 6 no. wooden work tables for AMS Lab.
- Providing & fixing MS grills in Ground floor balconies of new Guest house
- Internal painting of Phase-I housing complex including Flatelets
- Cleaning of Phase-I and Phase II housing Septic tanks by suction tankers
- Ceramic tile flooring in wash basin areas of all Sumeru-III flats
- Painting of corridors of Main building by OBD paint
- Painting of Pipe rack steel structure near Phase-I and Phase II Lab area
- Construction of Cricket pitch (by concrete paving) on N-side of IUAC playground
- PVC partition and sliding door in Server room of Computer area

### **3.10 HEALTH PHYSICS**

S.P. Lochab, R.G.Sonkawade and Birender Singh

Health physics is involved in the field of radiation research, development and safety aspects. The radiation safety aspects of accelerators in IUAC as per AERB regulation are maintained. This group has been providing academic and technical support towards radiation safety. Clearance from AERB has been obtained for installation of low energy particle accelerator.

For development of neutron shielding materials, different combinations of high density polyethylene (HDPE) with boron carbide powder in 10%, 20% and 30% ratio of boron are tried. Recently colemanite powder having natural boron is converted into slabs using resin as binder and some excellent results are expected in this study. A combination of HDPE, borated HDPE and lead+Iron in the ratio of 15:10:2 is calculated by MCNP

code for estimating the sliding door thickness for beam hall-II. Newly developed nanophosphors of TLD materials were studied for ion beam dosimetry purpose using 150 MeV proton beam at Joint Institute for Nuclear Research (JINR), Dubna, Russia.

There are some of the research activities a) Low background counting system b) End Window Grab Sampling Method & b) Neutron dosimetry with CR-39, etc. We are putting our efforts to update with time the necessary research instrumental facilities. We are going to start the calibration facility of Solid State Nuclear Track detectors (LR-115). Atomic Absorption Spectrometry (AAS) setup is being installed. Some of the important research activities are highlighted below. A few of the research scholars are doing their research under the guidance of this group.

One of our papers on “Nanoparticles of BaSO<sub>4</sub>:Eu for heavy-dose measurements” got a award from the deanship of scientific research, King Abdulaziz University, Jeddah. Most of the work for this research paper was done in health physics lab.

### **3.10.1 Nanoparticles of BaSO<sub>4</sub>:Eu for heavy-dose measurements.**

Numan Salah<sup>1</sup>, Sami S. Habib<sup>1</sup>, Zishan H. Khan<sup>1</sup>, Salim Al-Hamedi<sup>2</sup>, S.P. Lochab<sup>3</sup>

<sup>1</sup>Center of Nanotechnology, King Abdulaziz University, Jeddah 21589, Saudi Arabia

<sup>2</sup>Department of Biological Science, Faculty of Science, King Abdulaziz University, Jeddah 21589, Saudi Arabia

<sup>3</sup>Inter-University Accelerator Centre, Aruna Asaf Ali Marg, New Delhi

Nanoparticles of BaSO<sub>4</sub>:Eu with grain size in the range 30–50nm have been prepared by the chemical co-precipitation method and characterized by UV–visible spectrometry and X-ray diffraction (XRD). Shape and size of the prepared nanomaterials were observed by a scanning electron microscope (SEM). The optical energy band gaps of the micro- and nanocrystalline BaSO<sub>4</sub>:Eu were determined and are found to be 3.3970.0136 and 3.4870.0139 eV, respectively. The thermoluminescence (TL) glow curve of BaSO<sub>4</sub>:Eu nanoparticles has been studied and compared with that of the corresponding microcrystalline powder. It has been observed that the TL glow peak at 497 K, seen prominently in the microcrystalline sample, appeared as a small peak in nanocrystalline powder, while that observed as a shoulder in the former at 462 K dominates in the latter. The observed TL sensitivity of the prepared nanocrystalline powder is less than that of the microcrystalline sample at low doses, while it is more at higher doses. This nanophosphor exhibits a linear/sublinear TL response to g-radiation over a very wide range of exposures (0.1Gy to 7 KGy), which is much wider compared to that of the microcrystalline counterpart (0.1–10 Gy). This response over a large span of exposures makes the nanostructure form of BaSO<sub>4</sub>:Eu useful for its application to estimate low as well as high exposures of g-rays.

### 3.10.2 Thermoluminescence study of UV irradiated Ce doped SrS nanostructures

Ankush Vij<sup>1</sup>, S.P. Lochab<sup>2</sup>, Surender Singh<sup>1</sup>, Ravi kumar<sup>2</sup>, Nafa Singh<sup>1</sup>

<sup>1</sup>Department of Physics, Kurukshetra University, Kurukshetra

<sup>2</sup>Inter University Accelerator Centre, Aruna Asaf Ali Marg, New Delhi

Thermoluminescence (TL) study and kinetic analysis of UV irradiated Ce doped SrS nanostructures have been presented. Cerium concentration has been tuned to the maximum TL intensity. Cerium (0.5 mol%) doped SrS nanocrystalline phosphor exhibits a broad TL glow curve around 371K at a heating rate of 10 K/s. We noted that TL intensity increases with UV exposure time in the range 2 min–4 h and saturates between 4 h and 8 h of exposure which may be explained on the basis of track interaction model (TIM) and a high surface to volume ratio for the nanostructures. Further increase in the dose results into a decrease of TL intensity. The effect of different heating rates on the TL glow curve has also been investigated. The trapping parameters namely activation energy (E), order of kinetics (b) and frequency factor (s) for SrS:Ce (0.5 mol%) have been determined using glow curve deconvolution (GCD) functions.

### 3.10.3 Synthesis and the luminescence studies of Ce doped SrS nanostructures

Ankush Vij<sup>1</sup>, Surender Singh<sup>1</sup>, Ravi kumar<sup>2</sup>, S P Lochab<sup>2</sup>, V V S Kumar<sup>2</sup>, Nafa Singh<sup>1</sup>

<sup>1</sup>Department of Physics, Kurukshetra University Kurukshetra

<sup>2</sup>Inter University Accelerator Centre, Aruna Asaf Ali Marg, New Delhi

Cerium doped strontium sulfide nanostructures have been synthesized by solid state diffusion method in the presence of sodium thiosulphate. XRD confirmed the single phase rocksalt structure of synthesized samples and the average grain size using Debye Scherrer's relation is calculated to be 55 nm. TEM micrograph reveals the agglomerated whisker like morphology with a diameter of 55-60 nm and length of several nanometers which is in close agreement with XRD results. Effect of dopant concentration on photoluminescence (PL) intensity has been studied. PL emission for SrS:Ce (0.5 mol%) is at 481 nm with a shoulder at 530 nm at an excitation wavelength of 430 nm, which is attributed to the transitions from 5d state to 4f (2f7/2, 2f5/2) states of Ce<sup>3+</sup>. Ultraviolet and visible (UV-VIS) spectroscopy shows band to band absorption at 273 nm (4.54 eV) which is blue shifted in comparison to the band gap of bulk SrS (4.2 eV) which may be due to quantum confinement. Effect of high energy ball milling on the grain size and PL intensity has also been investigated for the first time in doped SrS system. PL emission wavelength is blue shifted by 3 nm but emission intensity decreases unexpectedly as the milling time increases, though there is size

reduction which is evident from XRD peaks broadening of milled samples. This may be assigned to surface defects generated by ball milling which act as killing centers, quenching the photoluminescence.

### **3.10.4 Luminescence studies and effect of etching on cerium doped CaS nanoparticles**

Geeta Sharma<sup>1</sup>, Puja Chawla<sup>1</sup>, S P Lochab<sup>2</sup> and Nafa Singh<sup>1</sup>

<sup>1</sup>Department of Physics, Kurukshetra University, Kurukshetra

<sup>2</sup>Inter University Accelerator Center, Aruna Asaf Ali Marg, New Delhi

Cerium doped calcium sulphide nanoparticles were synthesized using solid state diffusion method. The formed nanoparticles were characterized by XRD, TEM, UV-Visible Absorption Spectroscopy and PL spectroscopy. The XRD pattern confirmed cubic CaS phase with an average grain size of 53nm of the formed samples. TEM image showed non agglomerated particles with an average size of 60 nm which is in close agreement with XRD result. The PL emission spectrum showed peaks at 506nm and 565nm due to transition from the excited state to the ground state of Ce<sup>3+</sup>. The effect of etching has been studied on the luminescent properties of CaS: Ce phosphors. With increase in the etching time there is decrease in the size of the particles, as a result of which the PL spectrum show a slight blue shift. The UV-Visible absorption spectrum also shows blue shift with increase in etching time which is in agreement with nanosize effect.

### **3.10.5 Photoluminescence, thermoluminescence and Raman studies of CdS nanocrystalline phosphor**

Puja Chawla<sup>1</sup>, S.P. Lochab<sup>2</sup>, Nafa Singh<sup>1</sup>

<sup>1</sup>Department of Physics, Kurukshetra University, Kurukshetra

<sup>2</sup>Inter University Accelerator Centre, Aruna Asaf Ali Marg, New Delhi

This paper reports on the photoluminescence (PL), thermoluminescence (TL) and Raman spectra of cadmium sulphide (CdS) nanoparticles prepared by solid-state reaction. The structures and morphologies of the products were characterized by XRD, HRTEM and EDAX. XRD confirmed the single-phase formation of CdS nanoparticles. TEM micrograph revealed the formation of nearly spherical nanoparticles with a diameter of 3.5 nm. PL emission of CdS:Bi nanoparticles is at 413nm with a shoulder at 438nm in addition to CdS peak at 550 nm. This may correspond to transition from 3P<sub>1</sub> state to 1S<sub>0</sub> states of Bi<sup>3+</sup>. Thermoluminescence and Raman studies have also been carried out on CdS nanophosphor. The Raman spectrum of CdS nanoparticles clearly shows first, second and third order LO

Raman peaks when excited using the wavelength of 488 nm. The red shift of the Raman peaks in nanoparticles compared to that of bulk CdS may be attributed to optical phonon confinement.

### **3.10.6 Synthesis and Characterization of Bismuth doped Barium sulfide Nanoparticles**

Surender Singh<sup>1</sup>, Ankush Vij<sup>1</sup>, S.P.Lochab<sup>2</sup>, Ravi Kumar<sup>2</sup>, Nafa Singh<sup>1</sup>

<sup>1</sup>Department of Physics, Kurukshetra University, Kurukshetra

<sup>2</sup>Inter University Accelerator Center, Aruna Asaf Ali Marg, New Delhi

We have synthesized BaS:Bi nanocrystalline powder of average grain size 35 nm by solid state diffusion method using sodium thio-sulphate as a flux. During this work we have optimized the nature and amount of flux, amount of dopant and temperature of firing for maximum yield of photoluminescence. The samples were characterized by X-ray powder diffraction (XRD) method, transmission electron microscopy (TEM), photoluminescence (PL) and UV-Visible techniques. On excitation by 425nm, these nanophosphors give one emission peak at 575nm which corresponds to green color. In the excitation spectra of these particles there are two peaks at 350 nm and 425 nm. The effect of dopant concentration on the photoluminescence of BaS:Bi nanocrystallites has been studied which is in agreement with the principle of concentration quenching. The energy band gap of bismuth doped BaS nanopowder has been calculated to be 4.25eV and is blue shifted in comparison to their bulk counterparts. The blue shift may be due to the quantum confinement in the particles.

### **3.10.7 Thermoluminescence response and trap parameters determination of gamma exposed Ce doped SrS nanostructures**

Ankush Vij<sup>1</sup>, S.P. Lochab<sup>2</sup>, Ravi kumar<sup>2</sup>, Nafa Singh<sup>1</sup>

<sup>1</sup>Department of Physics, Kurukshetra University, Kurukshetra

<sup>2</sup>Inter University Accelerator Centre, Aruna Asaf Ali Marg, New Delhi

Thermoluminescence of Ce doped SrS nanostructures exposed to Co-60 gamma radiations (0.1 Gy to 7 kGy) has been investigated. TL glow curves for gamma doses in the range of 0.1–200 Gy, consist of a dominant peak at 386K with a very weak peak at 538K. At higher doses (1–7 kGy), the peak at 386K shifts to the higher temperature of 421 K, while the other peak at 538K becomes more intense. This anomalous shifting of the first peak from 386K to 421K has been explained in the framework of Chen's peak shape method. Kinetic analysis of the experimental TL glow curve has been carried out using glow curve deconvolution (GCD) functions to determine the trapping parameters.

### **3.10.8 Monitoring of radon and its progeny in the environment of the vertical 15UD Pelletron Accelerator facility.**

R.G. Sonkawade<sup>1</sup>, K. Kant<sup>2</sup>, Z. Papp<sup>3</sup>

<sup>1</sup>Inter University Accelerator Centre, Post Box 10502, New Delhi

<sup>2</sup>Dept. of Physics, K.L. Mehta Dayanand College for Women, Faridabad, Haryana

<sup>3</sup>Department of Env. Physics, University of Debrecen, Debrecen 4001, Hungary

Environmental radioactivity due to radon and its progenies in the ambient air at the vertical 15 UD Pelletron accelerator facility of the Inter University Accelerator Centre, New Delhi, India was evaluated to calculate the annual effective dose to the workers and users. The radon activity was measured with an active monitor. The activity concentrations of the radon progenies were measured simultaneously using grab aerosol sampling and absolute beta counting. The effect of in situ meteorological parameters such as the temperature and relative humidity along the height of the Pelletron tower on the activity of radon and its progenies was studied. The measurements were carried out in the winter and rainy seasons. The values for the temperature, relative humidity (in percentage), radon activity concentration, radon Equilibrium Equivalent Concentration (EEC), annual exposure, annual inhalation and annual effective dose were recorded/calculated for locations with air conditioning and without air conditioning. Elements such as <sup>218</sup>Po, <sup>214</sup>Pb, <sup>214</sup>Bi, radon and EEC activity concentrations were found to decrease with the height and relative humidity and increase with increasing temperatures. The dose levels observed in the facility were below the International Commission on Radiological Protection (ICRP) and United Nations Scientific Committee on the Effects of Atomic Radiation (UNSCEAR) recommendations, even for the general public (1.2 mSv).

### **3.10.9 Analysis of terrestrial naturally occurring radionuclides in soil samples from some areas of Sirsa district of Haryana, India using gamma ray spectrometry**

Rohit Mehra<sup>1</sup>, Sandeep Kumar<sup>2</sup>, Rajendra Sonkawade<sup>3</sup>, N. P. Singh<sup>2</sup>, Komal Badhan<sup>1</sup>

<sup>1</sup>Dept. of Physics, Dr. BR Ambedkar National, Institute of Technology, Jalandhar

<sup>2</sup>Dept. of Applied Sciences, Giani Zail Singh College of Eng. and Tech., Bathinda

<sup>3</sup>Health Physics Lab, Inter University Accelerator Centre, New Delhi

The activity concentration and the gammaabsorbed dose rates of the terrestrial naturally occurring radionuclides (<sup>232</sup>Th, <sup>226</sup>Ra and <sup>40</sup>K) were determined in soil samples collected from ten different locations of Sirsa district of Haryana, using HPGe detector based on highresolution gamma spectrometry system. The range of activity concentrations of <sup>226</sup>Ra, <sup>232</sup>Th and <sup>40</sup>K in the soil samples from the studied areas varies from 19.18 Bq kg<sup>-1</sup> (Moriwala) to 40.31 Bq kg<sup>-1</sup> (Rori), 59.43 Bq kg<sup>-1</sup> (Pipli) to 89.54 Bq kg<sup>-1</sup> (Fatehpur)

and 223.22 Bq kg<sup>-1</sup> (Moriwala) to 313.32 Bq kg<sup>-1</sup> (SamatKhera) with overall mean values of 27.94, 72.75 and 286.73 Bq kg<sup>-1</sup> respectively. The absorbed dose rate calculated from activity concentration of <sup>226</sup>Ra, <sup>232</sup>Th and <sup>40</sup>K ranges between 8.84 and 18.58, 37.02 and 55.78, and 9.24 and 12.97 nGy h<sup>-1</sup>, respectively. The total absorbed dose in the study area ranges from 60.40 to 82.15 nGy h<sup>-1</sup> with an average value of 70.12 nGy h<sup>-1</sup>. The calculated values of external hazard.

### **3.10.10 Use of Gamma-Ray Spectrometry for Assessment of Natural Radioactive Dose in Some Samples of Building Materials**

Komal Badhan<sup>1</sup>, Rohit Mehra<sup>1</sup>, Rajendra G Sonkawade<sup>2</sup>, and Surinder Singh<sup>1</sup>

<sup>1</sup>Dept. of Physics, Dr. B.R Ambedkar National Institute of Technology, Jalandhar

<sup>2</sup>Inter University Accelerator Center, Aruna Asaf Ali Marg, New Delhi

Samples of building materials (Granite, Bricks, Sand Stones) collected from Jalandhar area of Punjab have been analyzed for the primordial natural radionuclides viz. <sup>226</sup>Ra, <sup>232</sup>Th and <sup>40</sup>K using HPGe detector based on high-resolution gamma spectrometry system. The calculated average values of the total absorbed dose are 253.91 nGyh<sup>-1</sup>, 74.86 nGyh<sup>-1</sup> and 93.79 nGyh<sup>-1</sup> for samples of granite, bricks and sandstones respectively. The average values of indoor and outdoor annual effective dose for the present study of samples of granite, bricks and sandstones are 1.25 mSv and 0.31 mSv, 0.37 mSv and 0.09 mSv and 0.46 mSv and 0.12 mSv respectively. The calculated average value of the radium equivalent activity ( $Ra_{eq}$ ) for samples of bricks and sandstones are less and this value is higher for the granite samples than the safe limit (370Bq kg<sup>-1</sup>) recommended by Organization for Economic Cooperation and Development (OECD). Key Words: Building materials, Gamma-ray spectrometry, HPGe detector, Annual effective dose, External hazard index ( $H_{ex}$ ).

### **3.10.11 Measurement of Natural Radioactivity in Brick Samples Using Gamma-Ray Spectrometry**

Rohit Mehra<sup>1</sup>, Rajendra G Sonkawade<sup>2</sup>, Komal Badhan<sup>1</sup>, and Surinder Singh<sup>1</sup>

<sup>1</sup>Dept. of Physics, Dr. B.R Ambedkar National Institute of Technology, Jalandhar

<sup>2</sup>Inter University Accelerator Center, Aruna Asaf Ali Marg, New Delhi

The activity concentrations of primordial radio nuclides (<sup>226</sup>Ra, <sup>232</sup>Th and <sup>40</sup>K) have been determined for the brick samples of Jalandhar city of Punjab using HPGe detector based on high resolution gamma spectrometry system. The average activity concentration

values of  $^{226}\text{Ra}$ ,  $^{232}\text{Th}$  and  $^{40}\text{K}$  from the studied samples are  $21.38 \text{ Bq kg}^{-1}$ ,  $25.03 \text{ Bq kg}^{-1}$  and  $333.08 \text{ Bq kg}^{-1}$  respectively. The average value of radium equivalent activity ( $\text{Ra}_{\text{eq}}$ ) for studied brick samples is  $80.48 \text{ Bq kg}^{-1}$  which is less than the safe limit  $370 \text{ Bq kg}^{-1}$  recommended by Organization for Economic Cooperation and Development (OECD) equivalent to external gamma dose of  $1.5 \text{ mSvyr}^{-1}$ .

### **3.11 DATA SUPPORT LABORATORY**

V.V.V.Satyanarayana, R.Ruby Santhi and P.Sugathan

Data Support Laboratory provides user support to various experimental groups for setting up NIM & CAMAC modules for data acquisition. Data Room is providing two independent on-line data acquisition systems for data collection during Accelerator beam experiments and two more PCs for off-line analysis. Apart from providing regular user support and maintenance of the setup, we have developed a few electronic modules and serviced a number of NIM and CAMAC modules. The lab had procured new modules and cables and connectors for data acquisition purpose.

#### **3.11.1 Development of 4-Channel CAMAC module for Tesla Meter Readout**

Single-width CAMAC modules have been developed to interface the readout from digital Tesla meters (DTM) into the existing controls systems at IUAC. The single width module has input channels that can read four DTMs and display the magnetic field in the control system page. The circuit consists of an Atmega16 Micro-controller and RS232 interface circuits built on a single board. The micro-controller is programmed to accept the serial data from the Tesla meter and convert to parallel data. Data are stored in the registers and read by CAMAC commands. The GUI page for the read-back of the magnetic field from Injector magnet has been created and added to the Main Pelletron control system. Another module had been installed at the HYRA control system setup where currently two dipole magnetic fields are read and displayed onto the control system screen.

#### **3.11.2 Development of single width 8 channel CAMAC 4K ADC module**

A single-width CAMAC module with eight channels of peak sensing ADC (12 bit) has been developed for charged particle spectroscopy applications. The module design is based on FPGA and all the eight channels have been implemented on a single width CAMAC module. Figure shows the  $^{60}\text{Co}$  gamma spectrum acquired from a  $3''\times 3''$  NaI detector using this ADC.



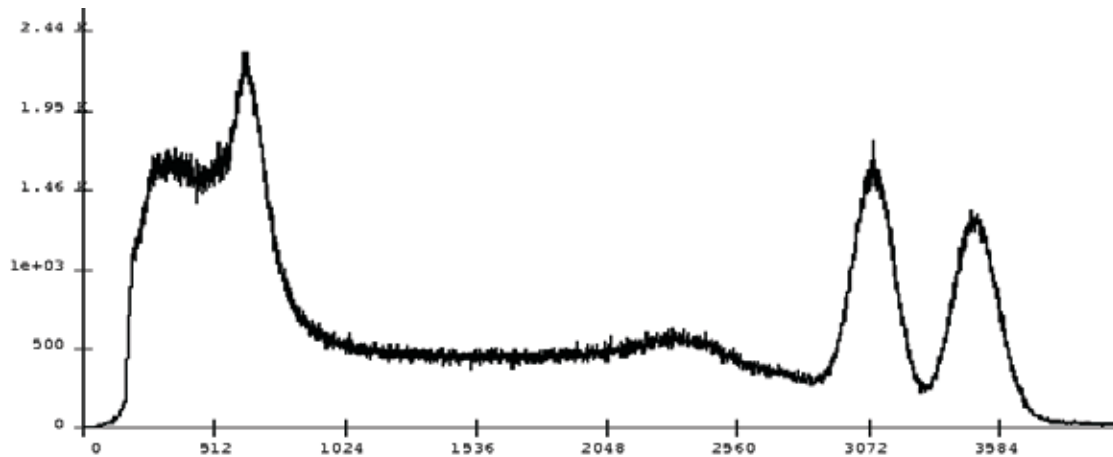

### 3.11.3 Development of 2-Channel Fast Rate Divider module

A single-width NIM module which incorporates two independent rate (frequency) dividers has been developed. We are in the process of testing this module. All inputs and outputs of this module are fast NIM compatible. The output signal has a rate which is equal to the input signal rate divided by the front-panel setting  $n$ , where  $n$  is any integer between 1 and 1000. The input-output propagation delay is typically 13ns, and it is independent of the  $n$  setting.

### 3.11.4 Servicing and Maintenance

During the year a number of electronic modules have been serviced and added to the existing inventory of the electronics pool.

Following modules has been serviced and made functional :

- TAC/ SCA module, EG&G Ortec model 567
- TAC module, EG&G Ortec model 566
- Delay module, EG&G Ortec model 425A
- Two numbers of 5 Inch Display Monitors

## 3.12 MECHANICAL WORKSHOP

B.B. Choudhary, S.K. Saini, R. Ahuja, Sunder Rao and Jimson Zacharias

The Mechanical Workshop is serving as an in house machining and welding facility for the 15 UD Pelletron accelerator laboratory, supporting various laboratories and large

number of user community. Workshop has been involved in developmental activities of new systems as well as a large-scale production of beam line components right from the inception of IUAC. Most of the beam line components used for the new beam lines was fabricated in the IUAC Workshop. Workshop continues to assist the entire in house fabrication activities of LINAC, RFQ and DTL for HCI, INGA, HYRA, HIRA as well as the Cryogenic component developments.

The major facilities of the workshop are the Machine shop, Welding shop and the state of art Electron Beam Welding (EBW) machine facility.

The Machine shop is equipped with a five axis Vertical Machining Centre and a CNC lathe. A Renishaw probing system is installed on the VMC. Apart from these, we have four conventional lathes, two milling machines and radial drilling machine catering to the tool room jobs. Most of these machines are of HMT make, fitted with DROs for achieving higher accuracy and better productivity. Apart from these, we have cylindrical grinder, tool and cutter grinder, horizontal and vertical band saw machines, etc. for general requirements. We also have the CAD facility, Solid Works for the design and the drafting purposes. We also have VISI CAM and PEPS for the CAM support for the Vertical Machining Centre and CNC lathe. A CMM is also installed in the workshop metrology section.

Welding shop is having high quality TIG welding machines and equipment. Some of the TIG machines can give pulsed arc for the thin section welding. Air plasma cutter with a capacity to cut up to 40mm thickness of stainless steel is used extensively. Aluminum welding and Oxy-acetylene cutting and brazing set ups are also available. We have a micro plasma machine from Air Liquide, France for very thin section welding.

The Electron Beam Welding facility is fully operational and fabrication of fifteen resonators has been completed successfully. Workshop personnel are involved in almost all the major ongoing projects.

IUAC workshop is providing apprentice training for the ITI passed students in both welding shop as well as in machine shop. Basic workshop training is provided for the scientist trainees and Ph.D. students enrolled in IUAC.